



T-Scale



Waterproof - Scale suitable for use outside

TN Crane Scales

General Specifications

- Display 30mm digits LCD display with LED backlight (TN-LCD)
- Capacities 600kg~12t
- Keyboard 5 keys(Mechanical switch)
- Housing Die-casting aluminum
- Max. Divisions 3x3,000d
- ADC Sigma delta
- ADC update $\leq 1/10$ second
- Operate Temp $-10^{\circ}\text{C} \sim +40^{\circ}\text{C}$
- Power AC adapter(12V/2500mA),
Rechargeable Li battery 7.4V 5200mA



Application: Tare, Hold, Accumulation, Weighing Units Conversion
Waterproof
Triple range (3 x 3000 divisions)
Internal Li-Ion rechargeable battery 60hrs continuous use (without backlight)
Remote Controller
Bluetooth
APP for mobile Phone
Records Management



TN Crane Scales

Model Name	Capacity	Readability	Division	Approx. weight
TN-600kg	150kg/300kg/600kg	0.05kg/0.1kg/0.2kg	3x3,000d	11kg
TN-3000kg	600kg/1500kg/3000kg	0.2kg/0.5kg/1kg	3x3,000d	11kg
TN-12000kg	3000kg/6000kg/12000kg	1kg/2kg/5kg	3x3,000d	25kg

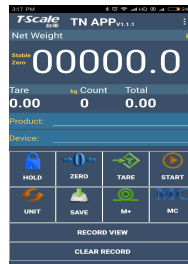
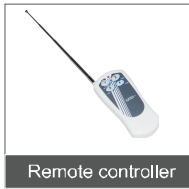

APP for android

Dimensions(mm)

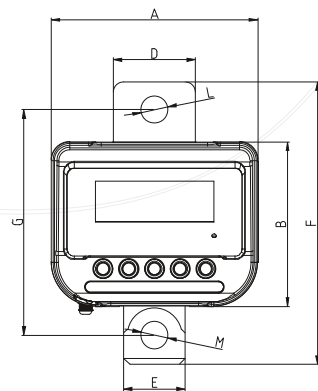
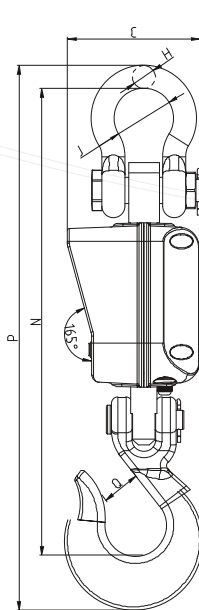
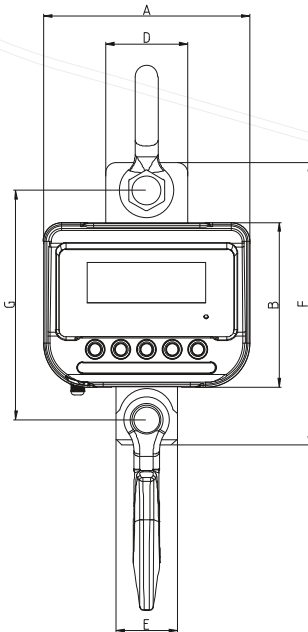

DTM (mm) CAP	600kg	3T	12T
A	201	201	201
B	160	160	160
C	128.5	128.5	128.5
D	80	80	95
E	60	60	80
F	270	275	330
G	219	219.5	247.5
H	φ 19	φ 22	φ 31.8
J	φ 50.8	φ 58	φ 82.5
L	φ 23	φ 26.5	φ 36
M	φ 23	φ 26.5	φ 36
N	415	456	557
P	477	532	660
Q	42.9	50.8	63.5